

Rittal – The System.

Faster – better – everywhere.

Compact Cooling Units



ENCLOSURES

POWER DISTRIBUTION

CLIMATE CONTROL

IT INFRASTRUCTURE

SOFTWARE & SERVICES

FRIEDHELM LOH GROUP



Rittal – The System.

Faster – better – everywhere.



Rittal – The System.

The whole is more than the sum of its parts.

The same is true of “Rittal – The System.” With this in mind, we have bundled our innovative enclosure, power distribution, climate control and IT infrastructure products together into a single system platform. Complemented by our extensive range of software tools and global service, we create unique added value for all industrial applications: Production plant, test equipment, facility management and data centres. In accordance with our simple principle, “Faster – better – everywhere” , we are able to combine innovative products and efficient service to optimum effect.

Faster – with our “Rittal – The System.” range of modular solutions, which guarantees fast planning, assembly, conversion and commissioning with its system compatibility.

Better – by being quick to translate market trends into products. In this way, our innovative strength helps you to secure competitive advantages.

Everywhere – thanks to global networking across 150 locations. Rittal has over 60 subsidiaries, more than 150 service partners with over 1,000 service engineers worldwide. For more than 50 years, we have been on hand to offer advice, assistance and product solutions.



Compact Cooling Units



Compact cooling units:

- High performance price rate
- RAL 7035
- Slim design, external / partial internal mounting
- Power supply with 220V, 1~ / 380V, 2~ ; 50Hz/60Hz
- Digital display controller for temperature and alarm
- Additional alarm signal output function, directly connect to power and signal lines
- New filter mat is simple and convenient for installation and replacement
- Louver design for air outlet
- High reliability for control system
- The third lab testing audit with standard: DIN 3168/EN815/EN14511, Ensure useful cooling capacity
- Eco-friendly refrigerant: R134a
- English and Chinese manual, two languages
- Stainless steel filter mat
- CE certificate
- Off the shelf
- Built in electric condensate evaporator, avoid condensate discharge problem
- Optional configuration: external electric condensate evaporator
- If need partial internal mounting, need to extra purchase mounting flange as installation accessories

Model No. SK		3370.220	3370.320	3370.370
Rated operating voltage			220V, 1~ 50Hz / 60Hz	
Dimensions in mm	W x H x D	280 x 550 x 125	280 x 550 x 180	280 x 550 x 265
Useful cooling output DIN 3168/EN 815	L35 L35 (°C)	300 W / 320 W	500 W / 525 W	700 W
	L35 L50 (°C)	150 W / 170 W	280 W / 350 W	520 W
Rated current		1.6 A / 1.8 A	2.1 A / 2.2 A	2.7 A / 2.7 A
Start-up current		3.0 A / 3.4 A	7.0 A / 7.4 A	9.0 A / 9.6 A
Power consumption DIN 3168	L35 L35 (°C)	290 W / 305 W	380 W / 390 W	430 W
	L35 L50 (°C)	350 W / 375 W	420 W / 400 W	515 W / 525 W
Refrigerant		R 134a, 100 g	R 134a, 170 g	R 134a, 280 g
Permissible operating pressure		35 bar	35 bar	35 bar
Temperature range		20°C ~ 50°C	20°C ~ 50°C	20°C ~ 50°C
Protection category EN 60529	Internal circuit	IP 54	IP 54	IP 54
Weight		13 kg	17 kg	22 kg
Colour		RAL 7035	RAL 7035	RAL 7035
Accessories				
External electric condensate evaporator			1194.358	
Partial internal mounting flange		1194.384	1194.385	1194.386

Compact Cooling Units

Model No. SK		3370.420	3370.424
Rated operating voltage		220V, 1~ 50Hz / 60Hz	380V, 2~ 50Hz / 60Hz
Dimensions in mm	W x H x D	400 x 950 x 230	
Useful cooling output DIN 3168/EN 815	L35 L35 (°C)	1200 W / 1250 W	1200 W / 1250 W
	L35 L50 (°C)	800 W / 830 W	800 W / 830 W
Rated current		4.0 A / 4.6 A	2.0 A / 2.6 A
Start-up current		20 A / 22 A	14 A / 15 A
Power consumption DIN 3168	L35 L35 (°C)	650 W / 715 W	650 W / 715 W
	L35 L50 (°C)	760 W / 850 W	760 W / 850 W
Refrigerant		R 134a, 325 g	R 134a, 325 g
Permissible operating pressure		35 bar	35 bar
Temperature range		20°C ~ 50°C	20°C ~ 50°C
Protection category EN 60529	Internal circuit	IP 54	IP 54
Weight		42 kg	44 kg
Colour		RAL 7035	RAL 7035
Model No. SK for built in electric condensate evaporator		1194.420	1194.424

Accessories

External electric condensate evaporator	1194.358
Partial internal mounting flange	1194.387

Model No. SK		3370.520	3370.524
Rated operating voltage		220V, 1~ 50Hz / 60Hz	380V, 2~ 50Hz / 60Hz
Dimensions in mm	W x H x D	400 x 950 x 250	
Useful cooling output DIN 3168/EN 815	L35 L35 (°C)	1600 W / 1650 W	1600 W / 1650 W
	L35 L50 (°C)	1100 W / 1150 W	1100 W / 1150 W
Rated current		5.7 A / 6.0 A	3.0 A / 3.5 A
Start-up current		22 A / 23 A	16 A / 16.5 A
Power consumption DIN 3168	L35 L35 (°C)	745 W / 830 W	745 W / 830 W
	L35 L50 (°C)	830 W / 915 W	830 W / 915 W
Refrigerant		R 134a, 650 g	R 134a, 650 g
Permissible operating pressure		35 bar	35 bar
Temperature range		20°C ~ 50°C	20°C ~ 50°C
Protection category EN 60529	Internal circuit	IP 54	IP 54
Weight		42 kg	42 kg
Colour		RAL 7035	RAL 7035
Model No. SK for built in electric condensate evaporator		1194.550	1194.554

Accessories

External electric condensate evaporator	1194.358
Partial internal mounting flange	1194.387

Model No. SK		3370.620	3370.724
Rated operating voltage		220V, 1~ 50Hz / 60Hz	380V, 2~, 50Hz
Dimensions in mm	W x H x D	400 x 950 x 250	400 x 1580 x 280
Useful cooling output DIN 3168/EN 815	L35 L35 (°C)	2000 W / 2080 W	3500 W
	L35 L50 (°C)	1452 W / 1520 W	2300 W
Rated current		6.0 A / 6.7 A	4.8 A
Start-up current		22 A / 23 A	31 A
Power consumption DIN 3168	L35 L35 (°C)	925 W / 1020 W	1850 W
	L35 L50 (°C)	1085 W / 1195 W	2050 W
Refrigerant		R 134a, 650 g	R 134a, 800 g
Permissible operating pressure		35 bar	35 bar
Temperature range		20°C ~ 50°C	20°C ~ 50°C
Protection category EN 60529	Internal circuit	IP 54	IP 54
Weight		50 kg	70 kg
Colour		RAL 7035	RAL 7035
Model No. SK for built in electric condensate evaporator		1194.620	1194.724

Accessories

External electric condensate evaporator	1194.358
Partial internal mounting flange	1194.387

We reserve the right to make technical modifications.

Compact Cooling Units

Useful cooling output 300W 3370.220

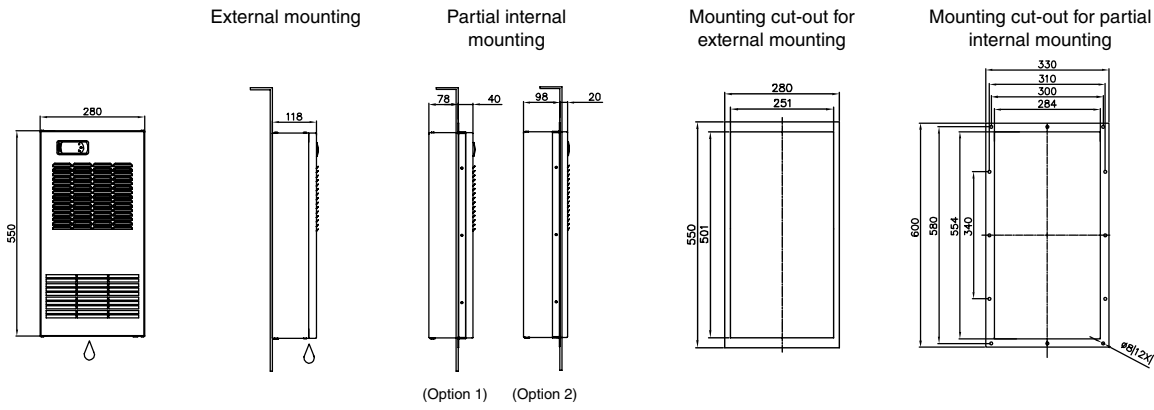

Useful cooling output 500W 3370.320

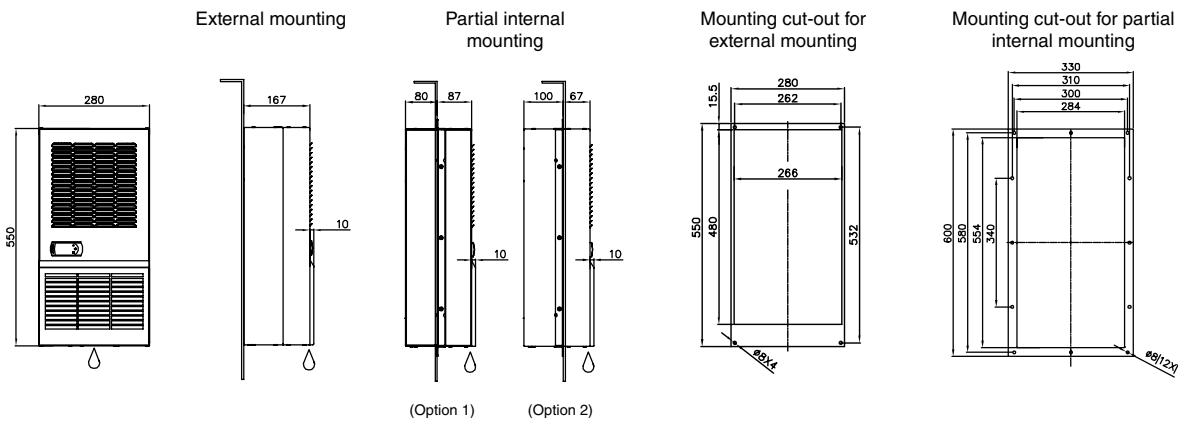

Useful cooling output 700W 3370.370

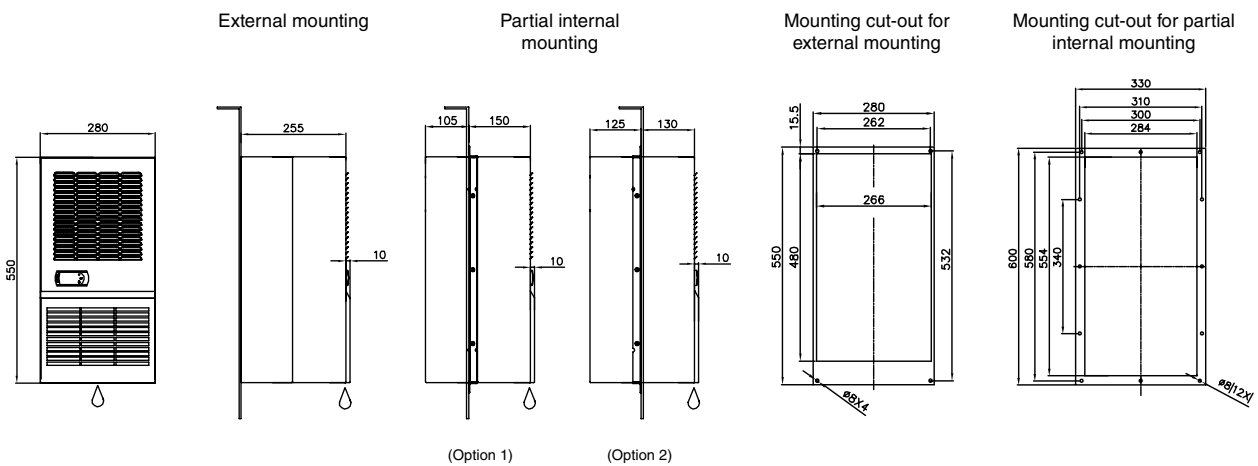

Compact Cooling Units

Useful cooling output 1200W 3370.420/424, 1194.420/424

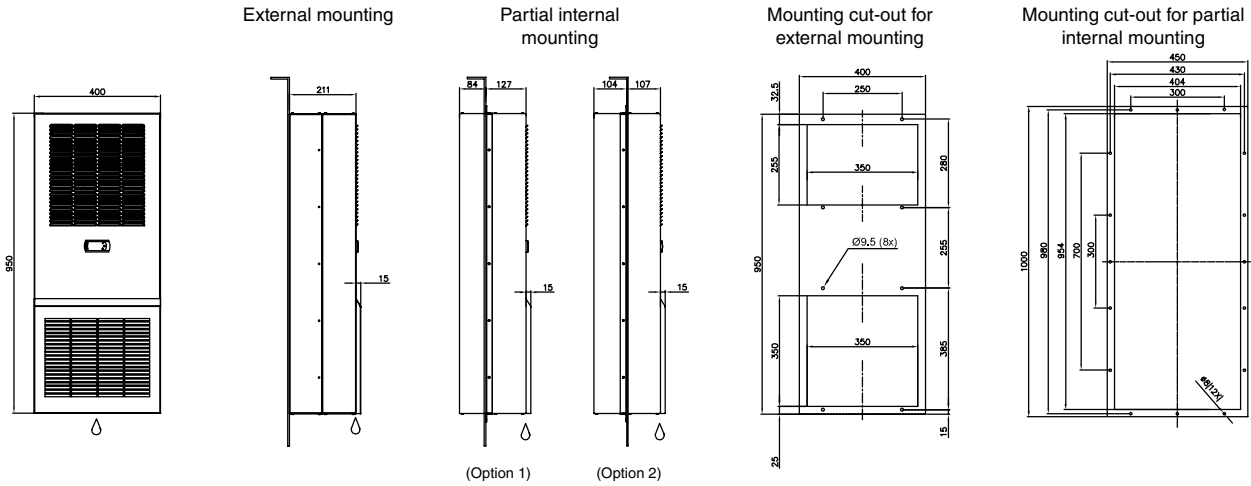

Useful cooling output 1600W / 2000W 3370.520/524/620, 1194.550/554/620

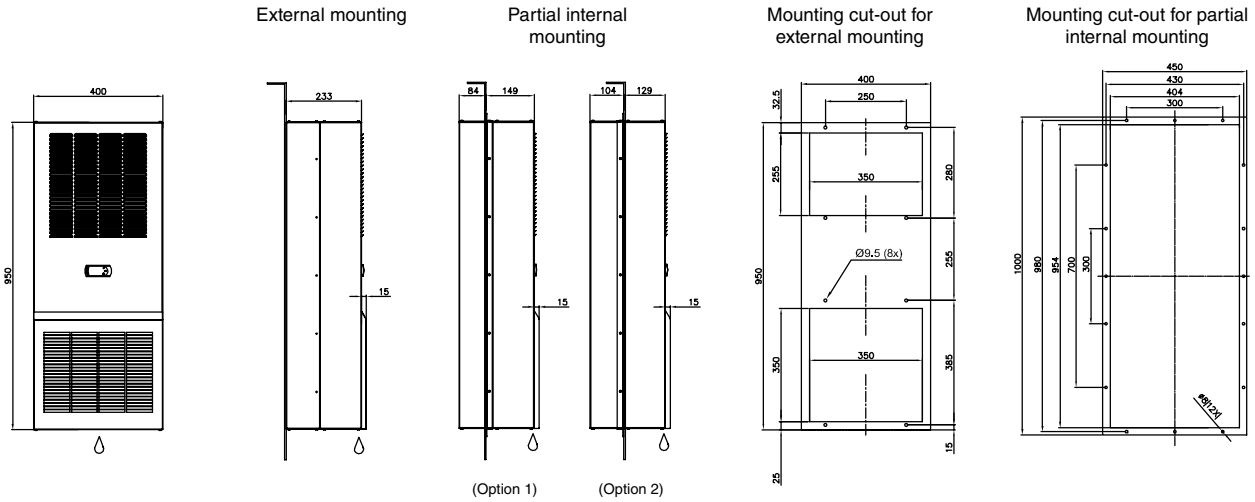

Useful cooling output 3500W 3370.724, 1194.724

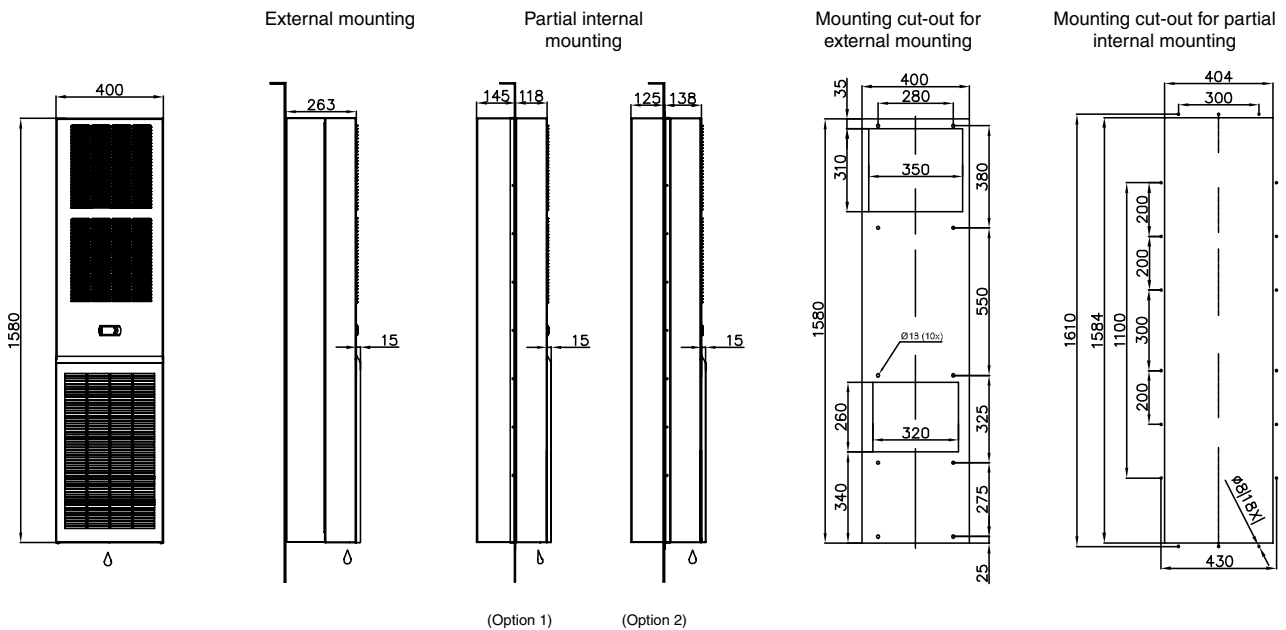

Rittal – The System.

Faster – better – everywhere.

- Enclosures
- Power Distribution
- Climate Control
- IT Infrastructure
- Software & Services

You can find the contact details of all Rittal companies throughout the world here.



www.rittal.com/contact

ENCLOSURES

POWER DISTRIBUTION

CLIMATE CONTROL

IT INFRASTRUCTURE

SOFTWARE & SERVICES

